



REBECCA ELDER

REBECCA@ELDERPRESERVATION.COM

**CARE OF BOOKS AND
SCRAPBOOKS**

ON TODAY'S AGENDA

- ▶ Book Structure
- ▶ Care and Handling of Books
- ▶ Scrapbook Structure
- ▶ Care and Handling of Scrapbooks
- ▶ Resources



THE CLASSICS

BOOKS

BOOK HISTORY

- ▶ The codex was created in early 2nd Century AD and used until the 11th Century.
- ▶ Gutenberg Bible printed in 1455 AD and ushered in the print era.
- ▶ Earliest publisher's cloth bindings published in 1821.
- ▶ Earliest paperbacks published in 1830.



By Ratbasket at English Wikipedia,

BOOK TECHNOLOGY

- ▶ Papermaking invented in 105 AD
- ▶ First paper making in Europe by 11th Century
- ▶ Paper making machine patented in 1806
- ▶ Alum rosin size introduced in 1807
- ▶ Wood pulp paper introduced in 1843

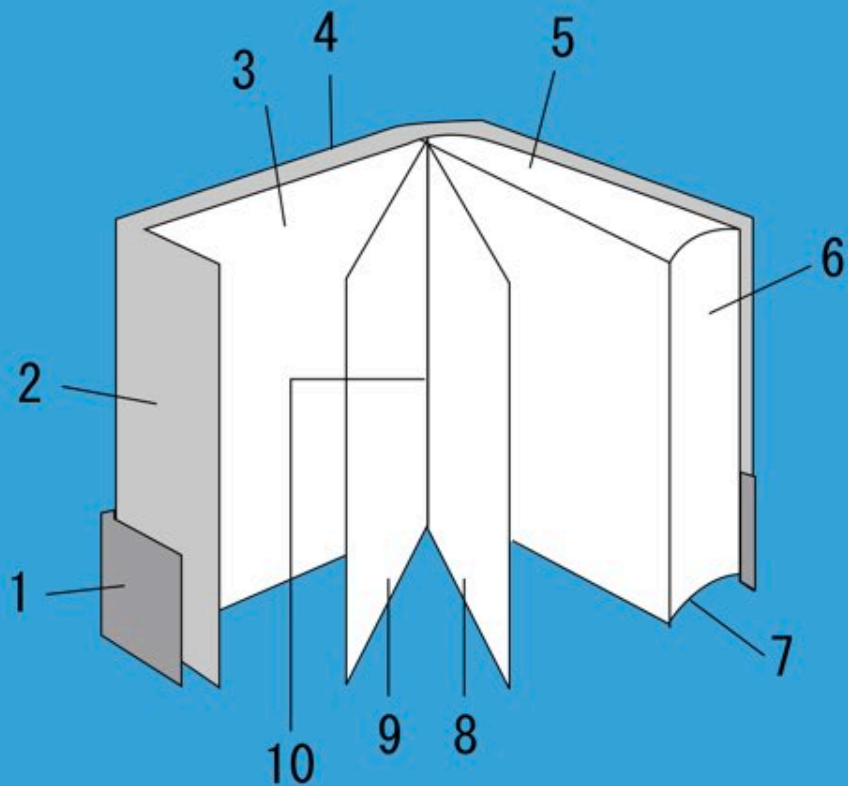

PARTS OF THE BOOK

Some common vocabulary

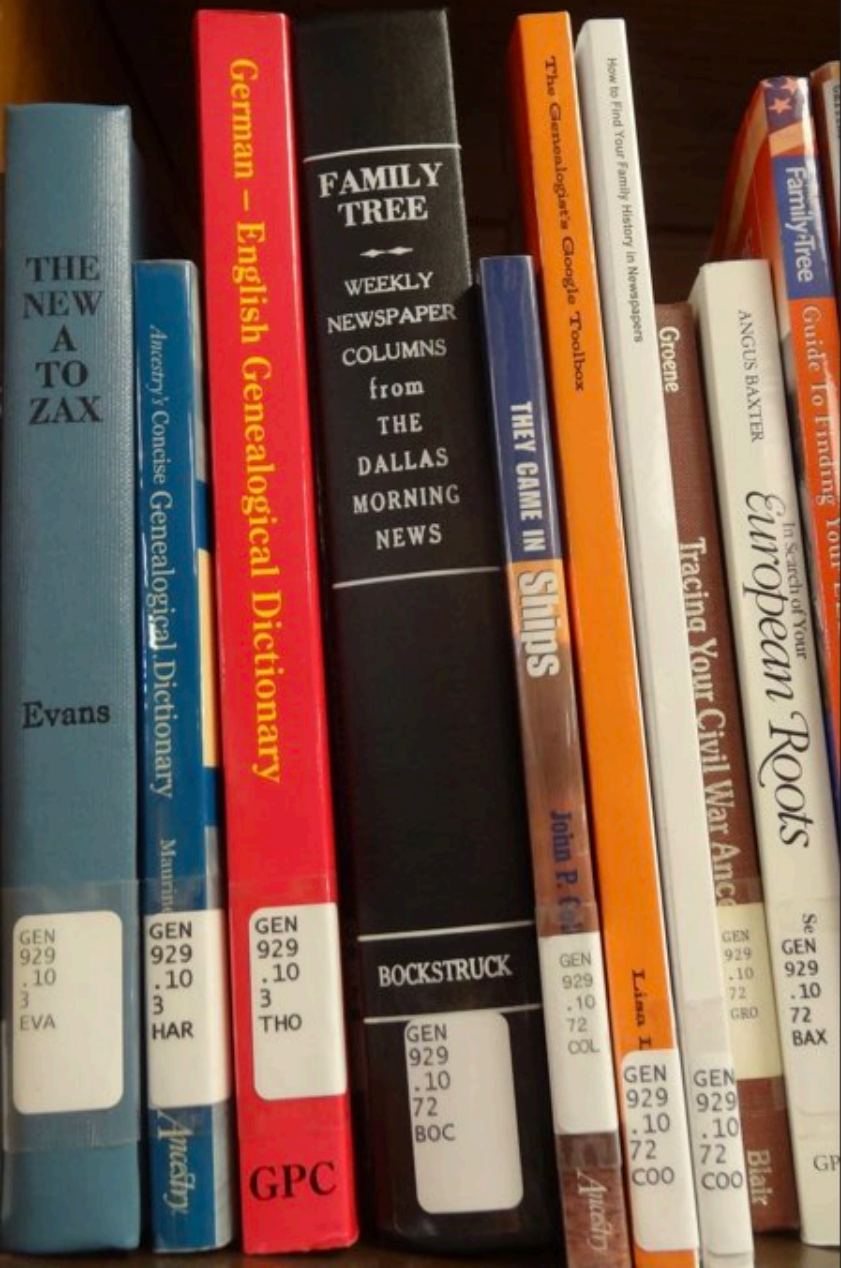

CARE AND HANDLING

BOOKS

COMMON FORMS OF DAMAGE TO BOOKS

- ▶ Textblock separates from the case
- ▶ Damage to top of spine
- ▶ Detached covers
- ▶ Torn pages
- ▶ Torn endsheets

SHELVING BOOKS

- ▶ Make sure that books are straight up and down on the shelves.
- ▶ Use bookends to keep shelves tidy and books from leaning.
- ▶ Shelf books by size.
- ▶ If a book is too large to fit on the shelf, shelf spine down or with oversized materials.
- ▶ Remove books from shelf by pushing the volumes on either side back and pulling from the spine.
- ▶ Avoid wooden shelving.

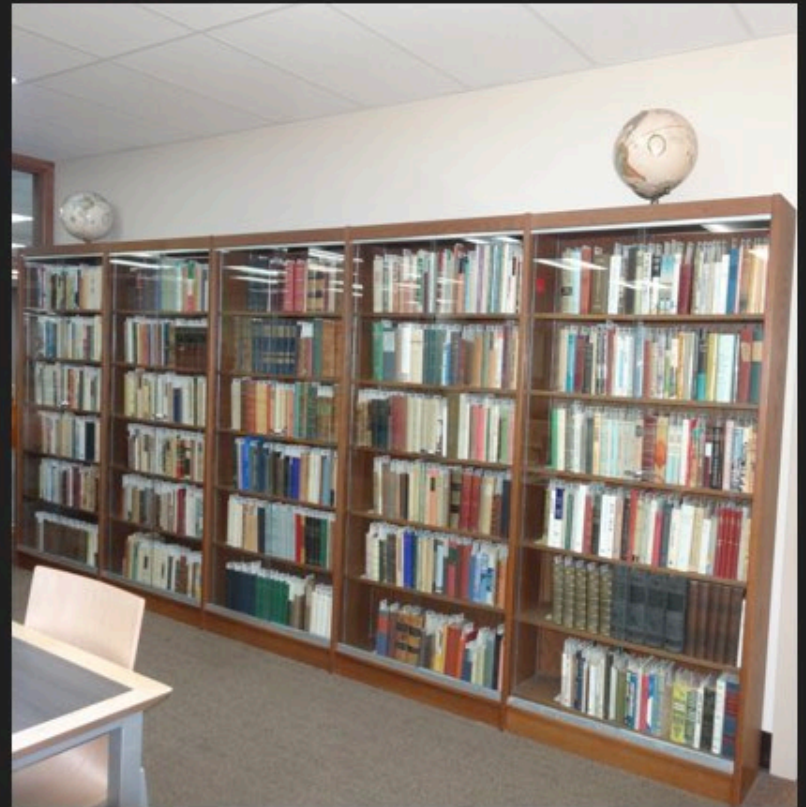

SHELVING OVERSIZED BOOKS

- ▶ Oversized books should be shelved horizontally.
- ▶ Ideally, shelve no more than three high.
- ▶ Shelve the largest book on the bottom.
- ▶ Remove individually to reach books at bottom.
- ▶ Always transport on book trucks.



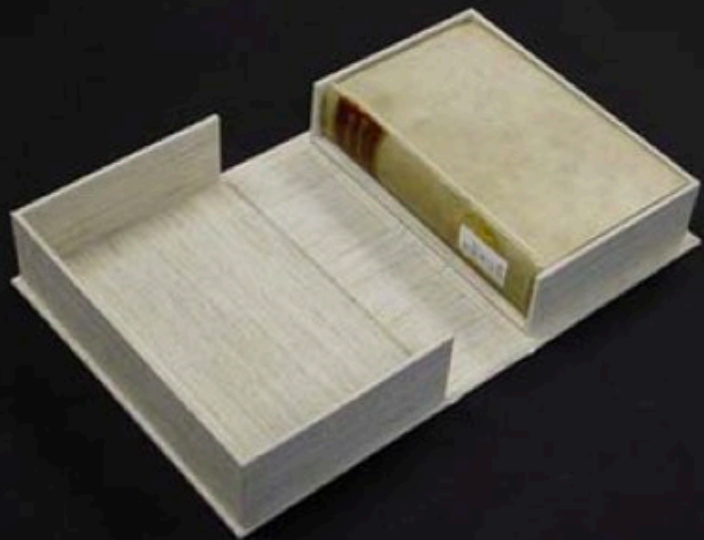

courseweb.lis.illinois.edu

BOOK BOXES

www.universityproducts.com





USING BOOKS

How does the book open?

BOOK SUPPORTS

- ▶ Usually foam wedges of varying thicknesses and angles
- ▶ Used with weighted snakes to hold books open at best angle
- ▶ Useful for display and reading room



BOOK USE TIPS

- ▶ Use clean hands to handle books. Gloves are not advised.
- ▶ Always leave books on support when reading them. Do not hold them off the table.
- ▶ Do not use pressure- sensitive adhesives on special collections materials. This includes Post-It® Notes.
- ▶ Do not dog ear books or use acidic bookmarks.
- ▶ Transport books on trucks.
- ▶ Do not use leather dressings on books.



**AVOID
PHOTOCOPYING
RARE BOOKS**

EXHIBITING RARE BOOKS

- ▶ Exhibit rare books at low light levels (less than 50 lux).
- ▶ Use cradles if book will be displayed open.
- ▶ Use Mylar® strapping to hold pages in place, if needed.
- ▶ Turn pages regularly.

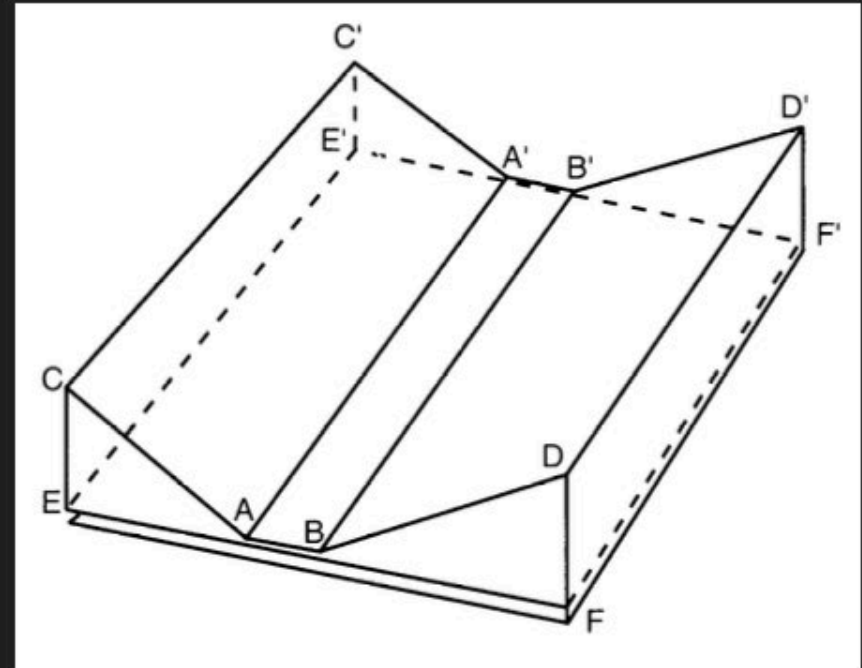

NPS Conserve-o-Gram 18/1



ADDED LAYERS OF
COMPLEXITY

**SCRAPBOOKS
AND ALBUMS**

SCRAPBOOKS AND ALBUMS

- ▶ Popular from Victorian era
- ▶ Many structure types
 - ▶ Sewn
 - ▶ Laced
 - ▶ Posts



MAGNETIC ALBUMS

- ▶ Adhesive coated pages with plastic overlays
- ▶ Ubiquitous from mid-20th century
- ▶ Extremely damaging to contents



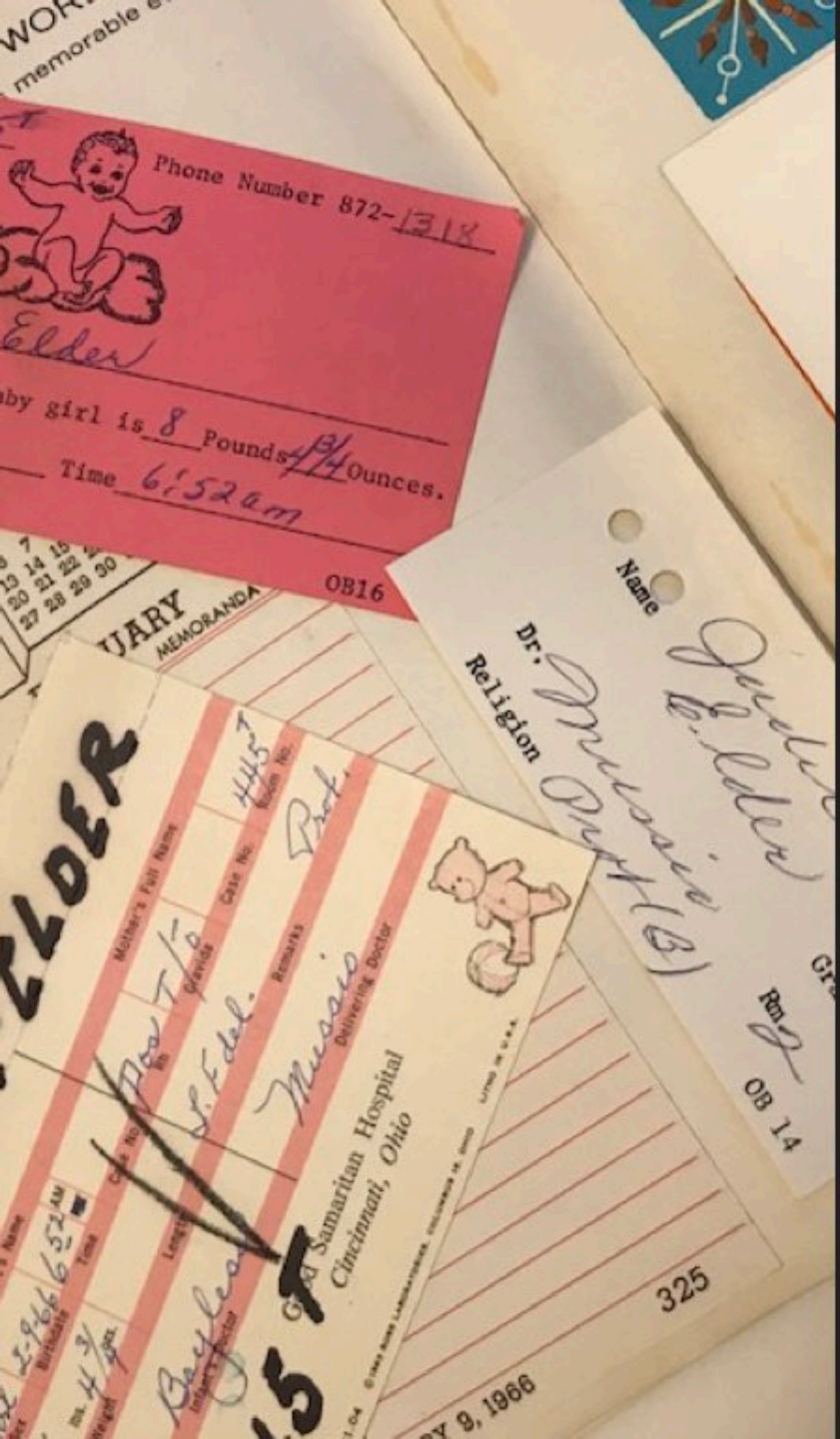

PHOTOGRAPHS
NEWS CLIPPINGS
RIBBONS
PRESSED FLOWERS
PROGRAMS AND TICKETS
LOCKS OF HAIR
AND SO MUCH MORE

**TYPES OBJECTS
FOUND IN ALBUMS**

COMMON FORMS OF DAMAGE TO SCRAPBOOKS

- ▶ Acid migration
- ▶ Brittle pages
- ▶ Failing adhesives
- ▶ Corroding staples or pins
- ▶ Overfull albums

OPTIONS FOR ALBUMS

- ▶ Rehousing
- ▶ Reformatting
- ▶ Recreating album
- ▶ Removing objects from album and storing separately



HOUSINGS FOR SCRAPBOOKS

- ▶ House in boxes
- ▶ Store flat
- ▶ Consider interleaving with Mylar or acid-free paper
- ▶ Consider removing posts or laces

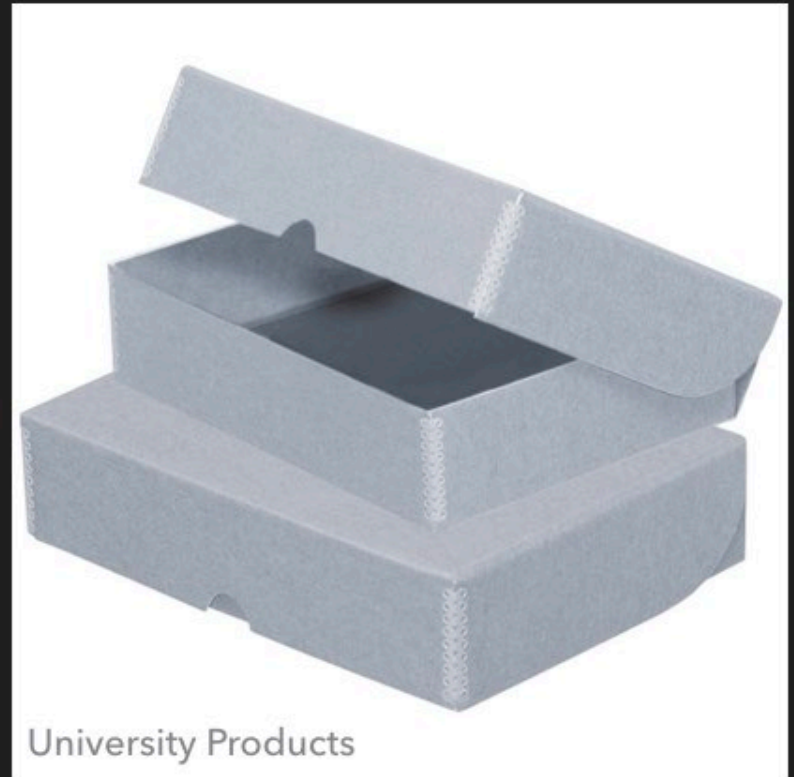

University Products

TO DISASSEMBLE OR NOT TO DISASSEMBLE?

- ▶ Is the scrapbook damaging the contents?
- ▶ What is the value of the scrapbook as an artifact?
- ▶ Can you safely remove the contents?



IF YOU DISASSEMBLE...

**Always create a digital
surrogate**

RESOURCES

- ▶ National Park Service Conserve-o-Grams
- ▶ NEDCC Preservation Leaflets
- ▶ LOC's Preservation of Scrapbooks and Albums
- ▶ ALCTS Preserving Scrapbooks
- ▶ Missouri State Archives Care of Scrapbooks
- ▶ AIC Conservation Wiki



THANK YOU!

- ▶ Let's stay in touch!
 - ▶ rebecca@elderpreservation.com
 - ▶ www.elderpreservation.com